

LACLUSIENNE C L U F I X

- Threaded elements, normalisation



www.laclusienne.com

Threaded elements, normalisation

This section contains information relative to the threading of LA CLUSIENNE-CLUFIX products and recommended tightening torques to guarantee optimal assembly performance.

Definitions

Threaded elements

A thread is obtained from a cylinder on which one (or several) helix groove(s) have been created.

The full section remaining is known as the **screw thread**.

A shank is described as being **'threaded'**, whilst a hole is described as being **'tapped'**.

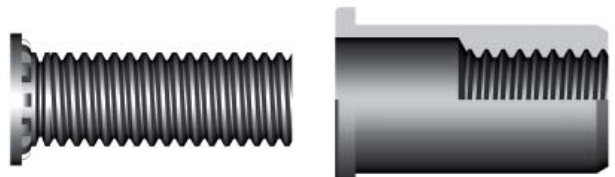

Screw (STUDFIX™)

Nut (CLUFIX®)

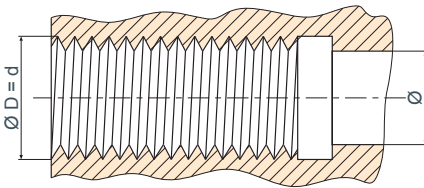
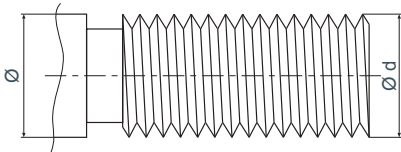

A threaded element is called a **screw or bolt**, and a tapped element is called a nut.

A **nut and screw or bolt system** enables two workpieces to be assembled in such a way that they can be dismantled.

The nominal diameter of a screw, bolt or nut is a notion that is used for designation purposes. The value of the nominal diameter corresponds, within the respective tolerances, to the outside diameter of the screw or bolt.

By definition, the screw, or bolt and nut have the same nominal diameter: **d = D**

Pitch

The standards provide for each nominal diameter to have a **fine or coarse pitch** (screws, bolts and nuts) as well as a small number of **fine pitches for exceptional purposes** (thread on thin tube, very short nut, screw or bolt for a measuring instrument).

Given equal nominal diameters, **the finer the pitch, the more reduce the tolerance, and the more precise the pitch is.**

The pitch of a screw, bolt or nut corresponds to the distance between two adjacent thread roots or crests.

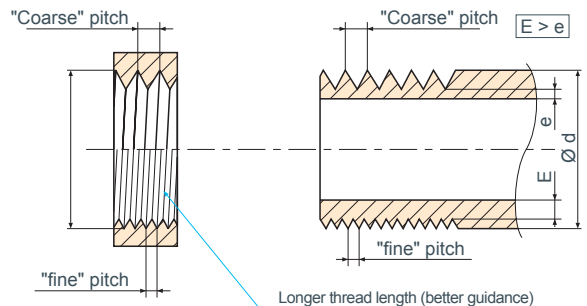

Helix direction

The helix direction is said to be 'right-threaded' if, on positioning the screw or bolt vertically, the thread climbs towards the right. It is said to be 'left-threaded' if the thread climbs towards the left. A right-threaded screw or bolt enters its immobilized nut through turning clockwise (anticlockwise for a left-threaded screw or bolt).

The standard LA CLUSIENNE-CLUFIX screw, bolt and nut families are manufactured with a 'right-threaded' helix direction.

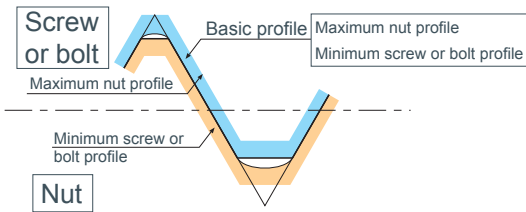

Thread profile

In order to ensure tight assembly with minimum clearance in all instances, the basic profile represents:

- for the screw or bolt, maximum profile;
- for the nut; minimum profile.

Metric threads

Designation of an ISO metric thread

The ISO metric thread is used for the majority of threaded components. Designation detail :

M symbol followed by nominal diameter (for example, $d = 8$) and pitch (for example $P = 1.25$) separated by the multiplication sign then followed by the grade (for example: 6) and the thread gap (for example g).

For a screw or bolt: M8 x 1.25 6g For a nut: M8 x 1.25 6H



Letter 'M' followed by nominal $\varnothing d$
Example : $d = 8$ mm

Pitch (distance between two threads)
Example : $P = 1.25$ mm

● Grade (3 to 9)
● Tolerance thread gap
e, f, g, h = For threads
G, H = For internal threads

For external threads, the gap is specified by a lower case letter, and for internal threads by a capital letter.

The tolerance system is expressed by fundamental tolerances which can be graded from 3 to 9 in accordance with diameter and by fundamental thread gaps marked H and G for internal threads, and e, f, g and h for external threads.

The LA CLUSIENNE-CLUFIX nut-type product families comply with the 6H tolerance system.

The LA CLUSIENNE-CLUFIX screw or bolt-type product families comply with the 6g tolerance system.

The table here after contains the ISO standardized dimensional thread data.

Designation of an ISO metric thread (suite)

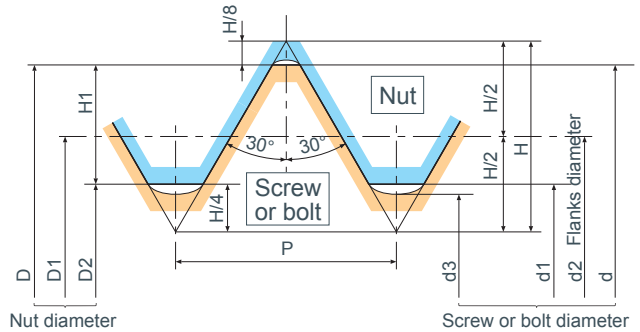

$d = D = \text{nominal diameter}$	$d2 = D2 = d - 0.6495 P$	$P = \text{Pitch}$	$H1 = 0.5412 P$
$d1 = D1 = d - 1.0825 P$	$d3 = d - 1.2268 P$	$H = 0.866 P$	$r = 0.1443 P$

All LA CLUSIENNE-CLUFIX component families comply with the ISO metric threads above.

Nominal dimensions (including pitch) of screw, bolt and nut families, are specified in the first column of the products data sheets.

The dimensions of standard external and internal threads of LA CLUSIENNE- CLUFIX products are compliant with the ISO 262 standard (ISO metric threads for general use - Selection of dimensions for screws, bolts and nuts).

d or D	Standardized dimensions (NF ISO 261 - NF ISO 262)										
	Coarse pitch thread (screws, bolts and nuts and other common applications) - H/6g tolerances (µm)									Fine pitch thread	
	Pitch	Core sectionmm ²	d2 = D2	Tolerances on d2		Tolerances on D2		D1	Tolerances on D1		Recommended fine pitches
Max.				Min.	Max.	Min.	Max.		Min.		
2	0.4	1.79	1.740	- 19	- 86	+ 90	0	1.567	+ 112	0	0.25
2.5	0.45	2.98	2.208	- 20	- 91	+ 95	0	2.013	+ 125	0	0.35
3	0.5	4.47	2.675	- 20	- 95	+ 100	0	2.459	+ 140	0	0.35
4	0.7	7.75	3.545	- 22	- 112	+ 118	0	3.242	+ 180	0	0.5
5	0.8	12.7	4.480	- 24	- 119	+ 125	0	4.134	+ 200	0	0.5
6	1.0	17.9	5.350	- 26	- 138	+ 150	0	4.918	+ 235	0	0.75
8	1.25	32.9	7.188	- 28	- 146	+ 160	0	6.647	+ 265	0	0.75 - 1
10	1.5	52.3	9.026	- 32	- 164	+ 180	0	8.376	+ 300	0	0.75 - 1 - 1.25
12	1.75	76.2	10.863	- 34	- 184	+ 200	0	10.106	+ 335	0	1 - 1.25 - 2.5
14	2.0	105	12.701	- 38	- 198	+ 212	0	11.835	+ 375	0	1 - 1.25 - 2.5
16	2.0	144	14.701	- 38	- 198	+ 212	0	13.835	+ 375	0	1 - 1.5

Other thread profiles



■ The CLUFIX® range of blind rivet nuts is also available in Unified Screw Thread profiles (UST), standard in the United States, Great Britain and Canada. This type of profile is coded UNC or UNF, depending on the pitch value:

- C: Coarse
- F: Fine

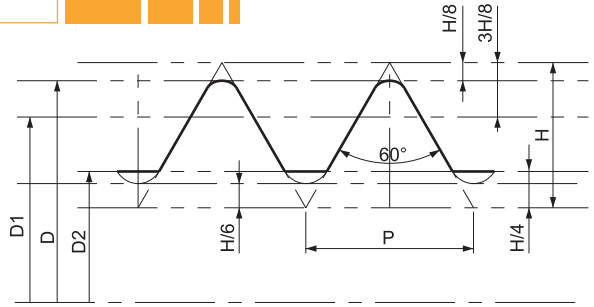

■ Designation of a UST thread:

- Diameter in inches or fractions of inches (for example: $\frac{1}{4}$ " - 1 inch = 25.4 mm)
- The specified pitch in number of threads to the inch (for example: 28)
- The UN symbol
- A letter, in accordance with pitch type (for example: C)
- A number designates the tolerance class, and the letter A or B indicates whether it is an internal or external thread.

For a screw or bolt: $\frac{1}{4}$ " - 28 UNF 2A

For a nut: 6-12 UNC 2B

The profile shape is identical to that of the metric profile.

1/4"

- 28

UNF

2A

Diameter in inches
Examples : $\frac{1}{4}$ ", 6...

Pitch (in number of threads per inch)
Examples : 28, 12...

● UN symbol
● Pitch type
F = Fine
C = Coarse

● Tolerance class (1 to 3)
● Tolerance thread gap
A = For threads
B = For internal threads

Tolerances:

For threads, there are 3 classes: 1A, 2A, 3A

For internal threads, there are 3 classes: 1B, 2B, 3B

Tolerance positions for the pitch diameters:

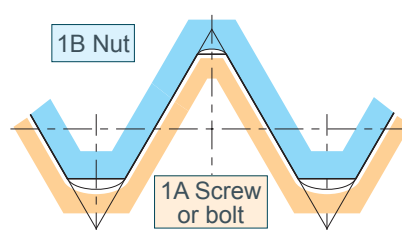
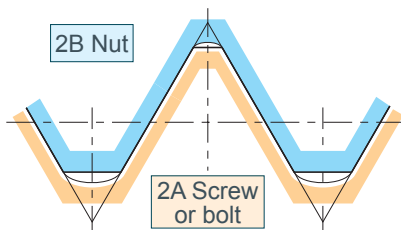
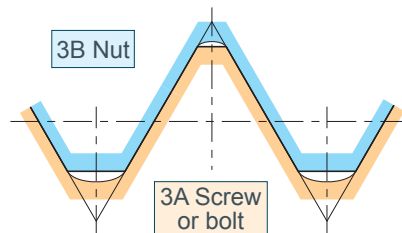

The two tables below contain standardized dimensional data (ANSI B1-1-1974 standard) for inch-dimension UNC and UNF threads:

UNC

Thread designation	Pitch in mm	nominal Ø	Ø pitch Δ
N° 1 - 64 f	0.3069	1.854	1.598
N° 2 - 56 f	0.4536	2.184	1.890
N° 3 - 48 f	0.5292	2.515	2.172
N° 4 - 40 f	0.6350	2.845	2.433
N° 5 - 40 f	0.6350	3.175	2.764
N° 6 - 32 f	0.7938	3.505	2.990
N° 8 - 32 f	0.7938	4.166	3.650
N° 10 - 32 f	1.0583	4.826	4.138
N° 12 - 32 f	1.0583	5.486	4.798
1/4" - 20 f	1.2700	6.350	5.525
5/16" - 18 f	1.4111	7.938	7.021
3/8" - 16 f	1.5875	9.525	8.494
7/16" - 14 f	1.8143	11.113	9.934
1/2" - 13 f	1.9538	12.700	11.430
9/16" - 12 f	2.1167	14.288	12.913
5/8" - 11 f	2.3091	15.875	14.376
3/4" - 10 f	2.5400	19.050	17.399
7/8" - 9 f	2.8222	22.225	20.391
1 - 8 f	3.1750	25.400	23.338
1 1/8" - 7 f	3.6286	28.575	26.218
1 1/4" - 7 f	3.6286	31.750	29.393
1 3/8" - 6 f	4.2333	34.925	32.174
1 1/2" - 6 f	4.2333	38.100	35.349

UNF

Thread designation	Pitch in mm	nominal Ø	Ø pitch Δ
N° 0 - 80 f	0.3175	1.524	1.318
N° 1 - 72 f	0.3528	1.854	1.626
N° 2 - 64 f	0.3969	2.184	1.928
N° 3 - 56 f	0.4536	2.515	2.220
N° 4 - 48 f	0.5292	2.845	2.502
N° 5 - 44 f	0.5773	3.175	2.799
N° 6 - 40 f	0.6350	3.505	3.094
N° 8 - 36 f	0.7056	4.166	3.708
N° 10 - 32 f	0.7938	4.826	4.310
N° 12 - 28 f	0.9071	5.486	4.897
1/4" - 28 f	0.9071	6.350	5.761
5/16" - 24 f	1.0583	7.938	7.249
3/8" - 24 f	1.0583	9.525	8.837
7/16" - 20 f	1.2700	11.113	10.287
1/2" - 20 f	1.2700	12.700	11.875
9/16" - 18 f	1.4111	14.288	13.371
5/8" - 18 f	1.4111	15.875	14.958
3/4" - 16 f	1.5875	19.050	18.019
7/8" - 14 f	1.8143	22.225	21.046
1 - 12 f	2.1167	25.400	24.026
1 1/8" - 12 f	2.1167	28.575	27.201
1 1/4" - 12 f	2.1167	31.750	30.376
1 3/8" - 12 f	2.1167	34.925	33.551
1 1/2" - 12 f	2.1167	38.100	36.726

For specific applications, LA CLUSIENNE-CLUFIX offers custom-made thread profiles (gas, trapezoid, etc.).

Recommended torque

- When an assembly is made, a torque (C_s) is applied to the screw or bolt and nut system, so that the force (F_o) generates a clamping force on the entire assembly. For a given torque (C_s) applied, the F_o value is dependent on the system's friction coefficient (μ).

The table here after (extract from the NF E 25-030 standard: Screw or bolt elements – Screwed assemblies – Design, calculation and assembly conditions) shows maximum recommended torque (in accordance with the assembled screw or bolt and nut elements).

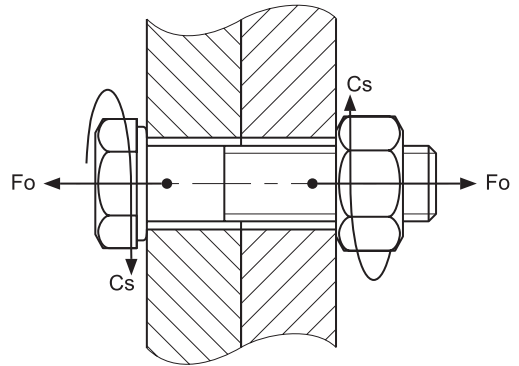

Grade	μ	Screw or bolt \varnothing	3	4	5	6	8	10	12	14	16
		Pitch	0.5	0.7	0.8	1	1.25	1.5	1.75	2	2
Grade	μ	Dimension across-flats	5.5	7	8	10	13	16	18	21	24
6.8 $R_m = 600 \text{ N/mm}^2$ $R_e = 480 \text{ N/mm}^2$	0.10	Cs (Nm)	0.71	1.65	3.25	5.6	13.6	27	46	75	115
		Fo (N)	1724	2988	4885	6896	12647	20128	29339	40280	55356
	0.15	Cs (Nm)	0.91	2.09	4.14	7.1	17.4	34	59	95	148
		Fo (N)	1556	2696	4414	6226	11432	18206	26550	36463	50216
	0.20	Cs (Nm)	1.06	2.42	4.81	8.3	20	40	69	111	174
		Fo (N)	1399	2422	3970	5598	10283	16382	23895	32822	45248
8.8 $R_m = 800 \text{ N/mm}^2$ $R_e = 640 \text{ N/mm}^2$	0.10	Cs (Nm)	0.95	2.20	4.34	7.5	18.2	36	62	99	153
		Fo (N)	2298	3985	6514	9195	16863	26838	39119	53707	73808
	0.15	Cs (Nm)	1.21	2.78	5.5	9.5	23	46	79	127	198
		Fo (N)	2075	3594	5836	8302	15242	24275	35401	48618	66955
	0.20	Cs (Nm)	1.41	3.22	6.4	11.1	27	53	92	148	232
		Fo (N)	1866	3230	5293	7464	13710	21843	31860	43763	60331
10.9 $R_m = 1000 \text{ N/mm}^2$ $R_e = 900 \text{ N/mm}^2$	0.10	Cs (Nm)	1.40	3.23	6.3	11	26	52	91	145	225
		Fo (N)	3376	5853	9568	13506	24768	39418	57457	78882	108406
	0.15	Cs (Nm)	1.79	4.09	8.1	14	34	67	116	187	291
		Fo (N)	3048	5279	8645	12194	22388	35655	51995	71408	98340
	0.20	Cs (Nm)	2.07	4.74	9.4	16.3	39	78	136	218	341
		Fo (N)	2740	4744	7774	10962	20137	32082	46795	64277	88611
12.9 $R_m = 1200 \text{ N/mm}^2$ $R_e = 1080 \text{ N/mm}^2$	0.10	Cs (Nm)	1.64	3.78	7.4	12.6	31	61	106	170	263
		Fo (N)	3951	6849	11196	15805	28984	46128	67236	92309	126858
	0.15	Cs (Nm)	2.09	4.79	9.5	16.4	40	79	136	219	341
		Fo (N)	3567	6178	10116	14269	26198	41724	60845	83563	115079
	0.20	Cs (Nm)	2.43	5.5	11	19.1	46	92	159	255	399
		Fo (N)	3207	5552	9098	12828	23565	37542	54760	75218	103964

R_m = tensile strength

R_e = elastic strength



COMPOSANTS D'ASSEMBLAGE
FASTENING SOLUTIONS

313 rue Louis Armand
BP 220 Z.I. des Grands Prés
74304 Cluses Cedex France
Tel. +33 (0)4 50 98 13 13
Fax. +33 (0)4 50 98 28 89
E-mail. commercial@clufix.com
www.laclusienne.com

